



Forniture Industriali - Macchine Utensili

DIEMIDIO

OMCN
S.p.A.

ready

FERRAMENTA
UTENSILERIA
ARTICOLI TECNICI

Made in Italy 



PROMOZIONE

Valida fino al 31.12.2022

Prezzi netti I.V.A. esclusa

24 MESI
Garanzia

24 MESI
Garanzia

OMCN
S.p.A.

MADE IN ITALY



SOLLEVATORI A CARRELLO

ART. K012 - 800 kg

~~€ 308,00~~ - € 183,00



ART. 112/A - 1500 kg

~~€ 594,00~~ - € 349,00



ART. 116 - 3000 kg

~~€ 831,00~~ - € 495,00

ART. 112/XR - 2000 kg

~~€ 782,00~~ - € 459,00

Completo di sicurezze meccaniche, ruote in nylon e supporto in acciaio ricoperto in gomma.



ART. 1120/E - 2000 kg

~~€ 1.323,00~~ - € 780,00

ART. 1120/F - 2000 kg

~~€ 1.010,00~~ - € 595,00

I Doppi rulli anteriori basculanti e le ruote posteriori girevoli in poliuretano, consentono di poter muovere i sollevatori anche sui grigliati e sono particolarmente indicati per interventi in fase di soccorsi stradali.



ART.		A mm	B mm	C mm	D mm	E mm	F mm	G mm	H mm	KG
K012	800 kg	415	95	290	85	170	120	585	500	14
112/A	1500 kg	525	135	345	290	100	200	650	780	36
112/XR	2000 kg	525	120	350	290	130	215	650	780	35
116	3000 kg	520	140	325	270	130	185	1280	920	56
1120/E	2000 kg	760	130	480	480	130	200	1080	910	65
1120/F	2000 kg	520	140	420	420	130	180	740	780	45

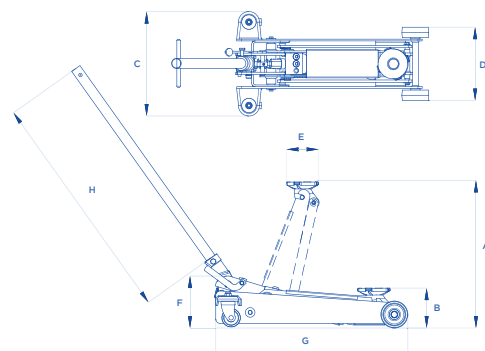

24 MESI
Garanzia

OMCN
S.p.A.

MADE IN ITALY



ART. 3000 - 2000 kg

~~€ 782,00~~ - € 459,00

SOLLEVATORI A CARRELLO TOP LINE

- Design completamente innovativo.
- Punti presa super ribassati.
- Manico ergonomico.
- Supporto piattello a base ampia.
- Piattello in gomma.
- Ruote in nylon.

ART. 3010 - 2000 kg

~~€ 1.477,00~~ - € 875,00

Dotato di ruote in poliuretano con doppi rulli basculanti anteriori.



ART. 3020 - 3000 kg

~~€ 1.078,00~~ - € 639,00



ART.		A mm	B mm	C mm	D mm	E mm	F mm	G mm	H mm	KG
3000	2000 kg	480	95	350	290	130	200	660	810	39
3010	2000 kg	710	95	480	485	130	210	1000	780	67
3020	3000 kg	505	90	290	275	130	145	1260	915	52

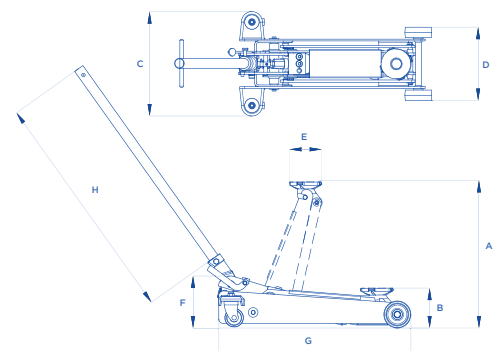

24 MESI
Garanzia

OMCN
S.p.A.

MADE IN ITALY



COLONNETTE DI SOSTEGNO



ART. 110 - 1000 kg

~~€ 50,50~~ - € 30,00

ART. 110/A - 1000 kg

~~€ 59,50~~ - € 35,00

ART. 110/B - 3500 kg

~~€ 111,00~~ - € 65,00

ART. 110/C - 3500 kg

~~€ 158,00~~ - € 93,00

ART.		MAX mm	MIN mm	KG
110	1000 kg	480	280	3
110/A	1000 kg	650	380	4
110/B	3500 kg	740	440	8
110/C	3500 kg	1170	700	11



ART. 215 - 15000 kg

~~€ 639,00~~ - € 379,00

ART. 216 - 15000 kg

~~€ 751,00~~ - € 445,00

HEAVY DUTY

ART.		MAX mm	MIN mm	KG
215	15000 kg	680	470	27
216	15000 kg	1170	680	36



ART. 217 - 20000 kg

~~€ 455,00~~ - € 269,00

ART. 218 - 20000 kg

~~€ 564,00~~ - € 334,00

HEAVY DUTY

ART.		MAX mm	MIN mm	KG
217	20000 kg	640	410	29
218	20000 kg	1080	670	32



ART. 111 - 300 kg

~~€ 313,00~~ - € 185,00

CAVALLETTO MOTORE

- Cavalletto per la revisione dei motori.
- Permette una rotazione di 360° del motore.
- Robusta struttura rinforzata in acciaio saldato.
- Fermo meccanico a vite per bloccare il motore in posizione.
- Braccetti di ancoraggio zincati a regolazione multipla per garantire una compatibilità assoluta.
- Vaschetta porta oggetti di serie.

ART. 239 - 8000 kg

~~€ 286,00~~ - € 169,00

ART. 239/A - 5000 kg

~~€ 241,00~~ - € 143,00

ART. 240 - 12000 kg

~~€ 344,00~~ - € 203,00

HEAVY DUTY



ART.		MAX mm	MIN mm	KG
239	8000 kg	740	450	18
239/A	5000 kg	740	450	13
240	12000 kg	740	450	25

24 MESI
Garanzia

OMCN
S.p.A.

MADE IN ITALY



SOLLEVATORI IDRAULICI DA FOSSA E SOTTOPONTE



- Stelo in acciaio speciale rettificato e cromato.
- Ruote di grandi dimensioni montate su cuscinetti per la massima manovrabilità.
- Valvola di protezione contro i sovraccarichi.
- Comando di discesa a velocità controllata "uomo presente".

ART. SIF 1/73 - 250 kg

~~€ 494,00~~ - € 289,00

ART. SIF 1/A/73 - 400 kg

~~€ 575,00~~ - € 339,00

ART. SIF 2/A/73 - 600 kg

~~€ 845,00~~ - € 495,00

ART. SIF 2/73 - 1000 kg

~~€ 966,00~~ - € 569,00

ART. SIF 3/73 - 1500 kg

~~€ 1.064,00~~ - € 625,00

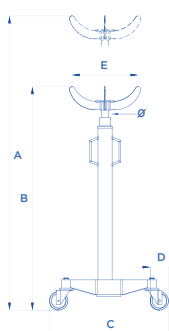

ART.		A mm	B mm	C mm	D mm	E mm	Ø mm	KG
SIF1/73	250 Kg	2090	1240	635x635	80	270	22	22
SIF1/A/73	400 Kg	2090	1300	635x635	80	270	24	27
SIF2/A/73	600 Kg	1960	1180	520x520	80	320	30	37
SIF2/73	1000 Kg	1990	1190	530x530	100	325	35	40
SIF3/73	1500 Kg	2020	1220	540x540	100	340	45	60

CULLA UNIVERSALE



ART.15/73 - 250 kg

~~€ 247,00~~ - € 145,00

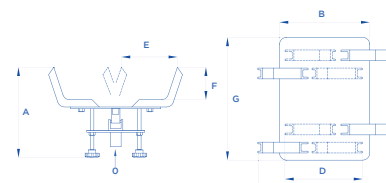

ART.		A mm	B mm	C mm	D mm	E mm	F mm	G mm	Ø mm	KG
15/73	250 kg	360	250	525	420	80	100	340	30	15



ART. SIF/XR IP - 100 kg

~~€ 1.865,00~~ - € 1.100,00

Sollevatori creati per smontare e rimontare in tutta sicurezza ruote di autovetture, veicoli commerciali e SUV posti su ponti sollevatori a due colonne o doppia forbice. L'azionamento è pneumatico. I rulli in materiale speciale sono registrabili in larghezza ed eccentrici per permettere il rapido posizionamento dei bulloni.

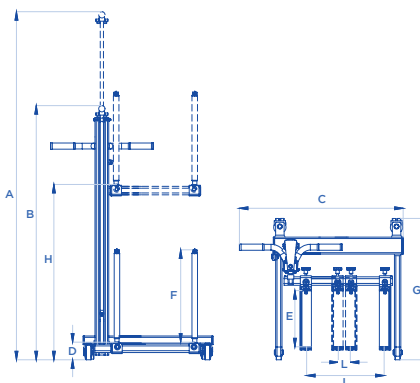

ART.			A mm	B mm	C mm	D mm	E mm	F mm	G mm	H mm	I mm	L mm	KG
SIF/XR IP	100 kg	8 - 10 bar	2100	1250	750	100	295	425	760	940	355	45	60

24 MESI
Garanzia

OMCN
S.p.A.

MADE IN ITALY



SOLLEVATORI IDRAULICI A BOTTIGLIA

- Nove modelli con portate da 3 a 50 ton.
- Struttura sovradimensionata in acciaio ad alta resistenza; la più solida sul mercato.
- Base d'appoggio di grandi dimensioni a garanzia della massima stabilità.
- Valvola di protezione contro i sovraccarichi incorporata.
- I modelli più pesanti sono dotati di maniglia per agevolare il trasporto.
- Avvicinamento al punto di sollevamento rapido e preciso grazie alla vite incorporata (escluso art. 125 - 125/A - 130/A).

ART. 125 - 3000 kg

~~€ 115,00~~ - € 68,00

ART. 126/A - 5000 kg

~~€ 132,00~~ - € 78,00

ART. 129 - 20000 kg

~~€ 321,00~~ - € 190,00

ART. 125/A - 3000 kg

~~€ 119,00~~ - € 70,00

ART. 127 - 10000 kg

~~€ 177,00~~ - € 105,00

ART. 130 - 30000 kg

~~€ 462,00~~ - € 273,00

ART. 126 - 5000 kg

~~€ 139,00~~ - € 82,00

ART. 128 - 15000 kg

~~€ 231,00~~ - € 137,00

ART. 130/A - 50000 kg

~~€ 1.241,00~~ - € 735,00

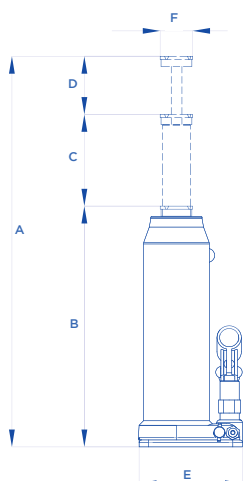

ART.		A mm	B mm	C mm	D mm	E mm	F mm	KG
125	3000 kg	325	200	125		120x120	40	4,8
125/A	3000 kg	400	240	160		120x120	40	5,2
126	5000 kg	485	220	140	125	120x120	40	5,5
126/A	5000 kg	370	190	105	75	120x120	40	5
127	10000 kg	515	240	150	125	140x140	50	8
128	15000 kg	515	245	150	120	140x140	60	10
129	20000 kg	575	285	165	125	170x170	60	18
130	30000 kg	585	295	165	125	225x183	65	25
130/A	50000 kg	430	270	160		280x230	90	53

24 MESI
Garanzia

OMCN
S.p.A.

MADE IN ITALY



GRU IDRAULICHE A CARRELLO PIEGHEVOLI

- Pieghevoli in pochi secondi, ingombro irrisorio in fase di riposizione.
- Lo stelo rettificato e cromato garantisce un'alta affidabilità nel tempo.
- Braccio allungabile in quattro posizioni di lavoro.
- Ruote posteriori girevoli per la massima manovrabilità.
- Gancio girevole a 360°.
- Valvola di protezione contro i sovraccarichi incorporata.
- Comando di discesa a velocità controllata.
- Pompa idraulica a due velocità.



ART. GP05/DE - 500 kg

~~€ 1.071,00~~ - € 630,00

ART. GP10/DE - 1000 kg

~~€ 1.507,00~~ - € 890,00



ART. GP12/DE - 1200 kg

~~€ 1.962,00~~ - € 1.160,00

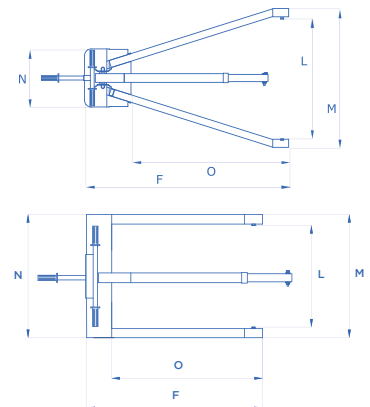
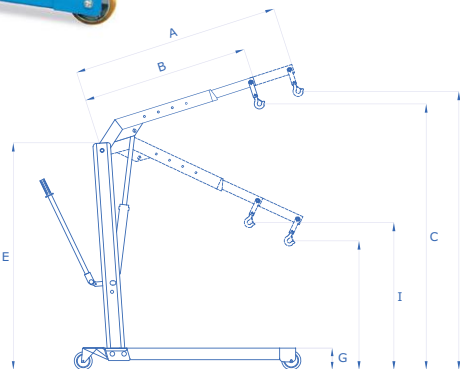

ART.				
GP05/DE	500 Kg	400 Kg	250 Kg	150 Kg
GP10/DE	1000 Kg	800 Kg	500 Kg	300 Kg
GP12/DE	1200 Kg	900 Kg	800 Kg	700 Kg

ART.		A mm	B mm	C mm	D mm	E mm	F mm	G mm	H mm	I mm	L mm	M mm	N mm	O mm	KG
GP05/DE	500 Kg	1300	1000	2130	2360	1570	1540	150	400	600	780	900	400	1160	80
GP10/DE	1000 Kg	1470	1170	2180	2320	1700	1740	180	550	725	840	980	450	1325	122
GP12/DE	1200 Kg	1490	1190	2140	2355	1600	1600	135	1450	1450	1005	1170	375	1110	125

24 MESI
Garanzia

OMCN
S.p.A.

MADE IN ITALY

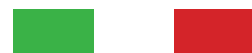

ART. SL/15 - 1500 kg

€ ~~2.192,00~~ - € **1.295,00**

ART. SL/20 - 2000 kg

€ ~~2.623,00~~ - € **1.550,00**

ART. SL/30 - 3000 kg

€ ~~4.971,00~~ - € **2.930,00**

GRU IDRAULICHE A CARRELLO

- Lo stelo rettificato e cromato garantisce un'alta affidabilità nel tempo.
- Braccio allungabile in quattro posizioni di lavoro.
- Ruote posteriori girevoli per la massima manovrabilità.
- Gancio girevole a 360°.
- Dotata di tiranti laterali.
- Valvola di protezione contro i sovraccarichi incorporata.
- Comando di discesa a velocità controllata.
- Pompa idraulica a due velocità.
- Dotata di ruote in poliuretano.

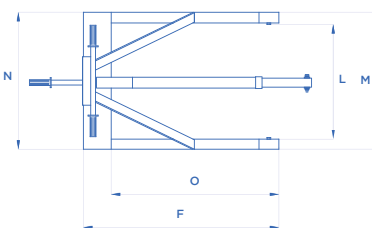
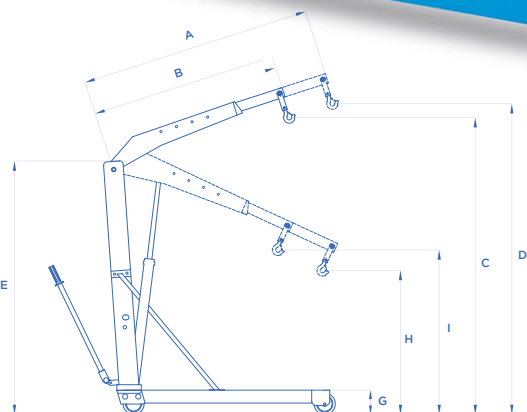
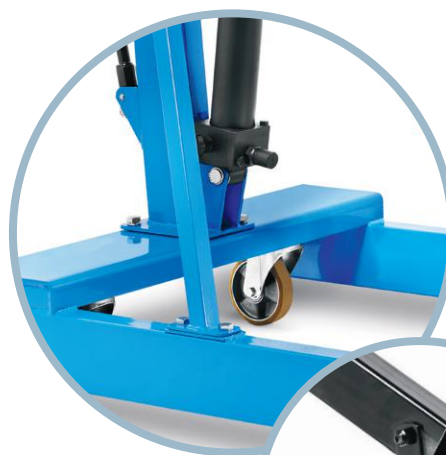

ART.				
SL/15	1500 kg	1200 kg	800 kg	500 kg
SL/20	2000 Kg	1500 Kg	1000 Kg	600 Kg
SL/30	3000 Kg	2400 Kg	1850 Kg	1300 Kg

ART.		A mm	B mm	C mm	D mm	E mm	F mm	G mm	H mm	I mm	L mm	M mm	N mm	O mm	KG
SL/15	1500 Kg	1815	1370	2470	2750	1865	1690	195	310	630	830	1015	1000	1450	190
SL/20	2000 Kg	1910	1460	2780	3110	1990	1910	215	315	645	940	1120	1100	1640	235
SL/30	3000 Kg	2280	1790	3300	3730	2150	2270	265	510	780	1170	1420	1400	1910	480

24 MESI
Garanzia

OMCN
S.p.A.

MADE IN ITALY



SOLLEVATORI PER MOTO

TOP
LINE

- Ferma ruota anteriore a sbalzo per agevolare il posizionamento della moto.
- **Morsa manuale in versione ribassata di serie su tutti i modelli.**
- Sistema di scorrimento su rulli pieni.
- **Scivolo retrattile per ridurre l'ingombro a terra quando il banco è sollevato.**
- Perni completi di ingrassatori.
- Finestra posteriore estraibile per facilitare l'estrazione della ruota.
- Protezione centrale antiscivolo in alluminio.
- Vaschette porta oggetti di serie.
- Dotati di cremagliera meccanica dentata di sicurezza.

ART. 196/P - 500 kg

~~€ 2.470,00~~ - € 1.475,00

CON POMPA IDRAULICA



ART. 196/PI - 500 kg

~~€ 3.347,00~~ - € 1.990,00

CON POMPA IDROPNEUMATICA



ART. 196/PL - 500 kg

~~€ 3.980,00~~ - € 2.340,00

CON POMPA ELETTROIDRAULICA



ART.				Motore trifase	
196/P	500 Kg	6 bar	1,5 kW	400V • 50HZ	210
196/PI	500 Kg	6 bar			200
196/PL	500 Kg	6 bar			230

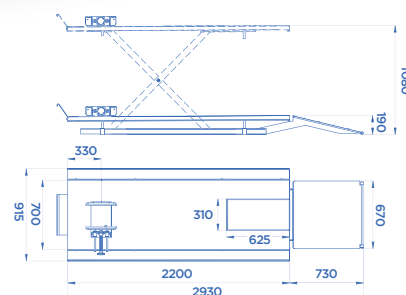

24 MESI
Garanzia

OMCN
S.p.A.

MADE IN ITALY



SOLLEVATORE PER MOTO

- Ferma ruota anteriore a sbalzo per agevolare il posizionamento della moto.
- **Morsa manuale in versione ribassata di serie.**
- **La struttura del basamento garantisce massima stabilità e minimo ingombro a terra.**
- Pompa idraulica a pedale ad innesto diretto per ridurre il tempo necessario al sollevamento.

**CLASSIC
LINE**



ART. 196 - 500 kg

~~€ 2.184,00~~ - € 1.290,00

CON POMPA IDRAULICA

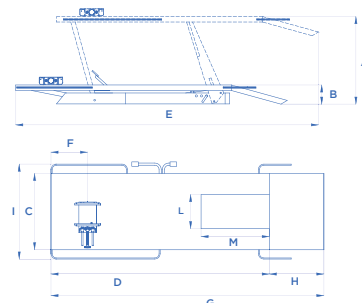

ART.		A mm	B mm	C mm	D mm	E mm	F mm	G mm	H mm	I mm	KG	
196		500 Kg	770	170	700	2000	2750	330	2500	500	870	165

ART. 561

~~€ 146,00~~ - € 86,00

Cavalletto di stazionamento libera ruota anteriore a braccetti snodati



ART. 562

~~€ 159,00~~ - € 93,00

**Cavalletto di stazionamento libera ruota posteriore registrabile in altezza e in larghezza
Completo di braccetti di appoggio e braccetti a forcella**



24 MESI
Garanzia

OMCN
S.p.A.

MADE IN ITALY



PRESSE IDRAULICHE CON POMPA A MANO

- Struttura in robusto acciaio saldato.
- Stelo del cilindro in acciaio speciale, trattato e cromato.
- Molla in acciaio inserita nel cilindro per un rapido ritorno dello stelo.
- Pompa a mano a due velocità: rapidità in fase di avvicinamento e precisione in fase di lavoro.
- Gestione delle due velocità tramite volantino posto sulla pompa.
- Massima versatilità grazie al bancale ad altezza regolabile.
- **Piatto cacciaspine e coppia di prismi a V forniti di serie.**

ART. 156+020 - 20 Ton.

€ 2.334,00 - € 1.375,00

ART. 156
Completa
di cilindro mobile



ART. P30/SA - 30 Ton.

€ 4.211,00 - € 2.470,00

ART. 157 - 40 Ton.

€ 5.393,00 - € 3.180,00

ART. P30/SA - 157
Complete di argano
per sollevare il bancale

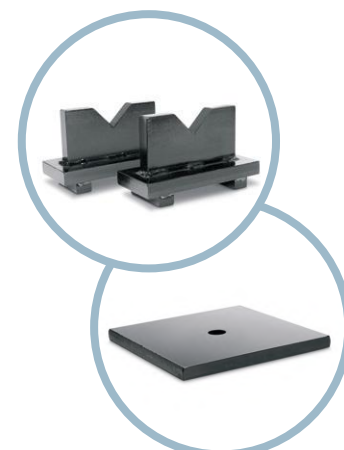
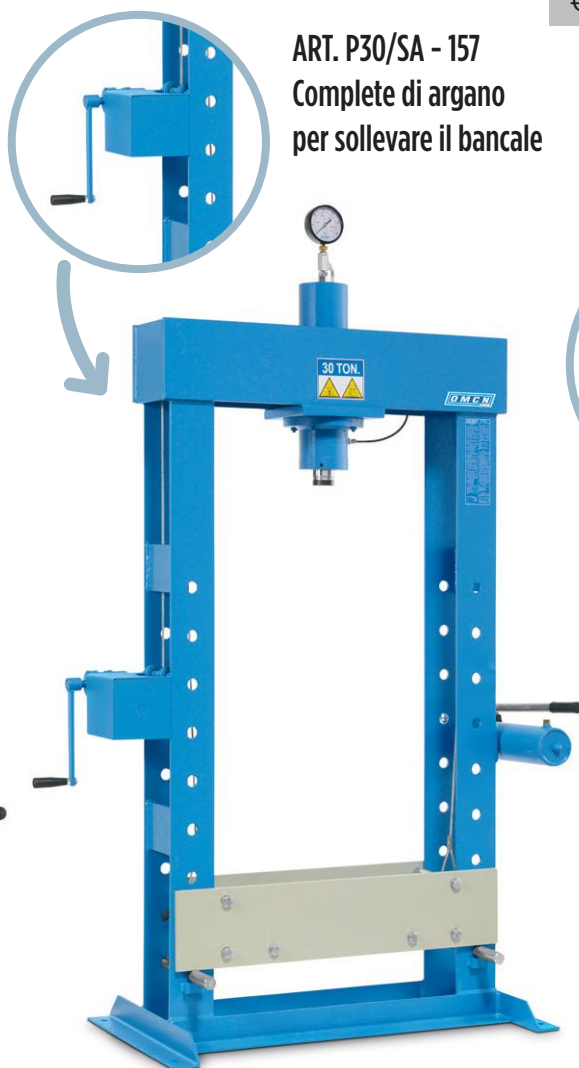

INCLUSI

ART.	TON	A mm	B mm	C mm	D mm	E mm	F mm	G mm	H mm	KG
156	20	1960	500	930	510	1020	140	200	50	150
P30/SA	30	2180	600	1300	695	1000	170	190	60	280
157	40	2260	850	1420	770	1135	200	190	60	405

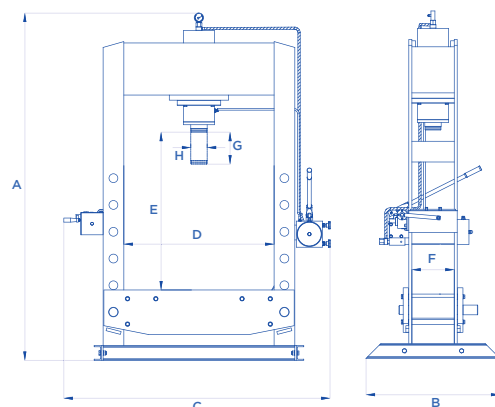

24 MESI
Garanzia

OMCN
S.p.A.

MADE IN ITALY



PRESSE ELETTROIDRAULICHE

- Stelo del cilindro in acciaio speciale, trattato e cromato.
- Centralina motorizzata a due velocità ad inserimento automatico.
- **Azionamento tramite distributore a leva a 3 posizioni.**
Questa soluzione permette di avere una mano libera per lavorare.
- Dotate di valvola di taratura per regolare la potenza in base alla lavorazione da eseguire.
- Massima versatilità grazie al bancale ad altezza regolabile.
- Sollevamento del bancale tramite apposito argano.
- **Piatto cacciaspine e coppia di prismi a V forniti di serie.**
- Manometro fornito di serie.

ART. 162/W - 50 Ton.

€ ~~10.336,00~~ - € **6.090,00**

ART. 164/W - 100 Ton.

€ ~~15.380,00~~ - € **9.100,00**

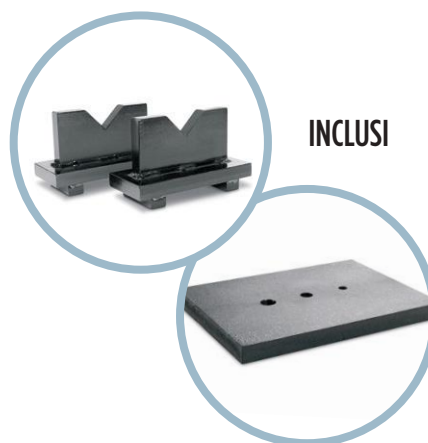

INCLUSI

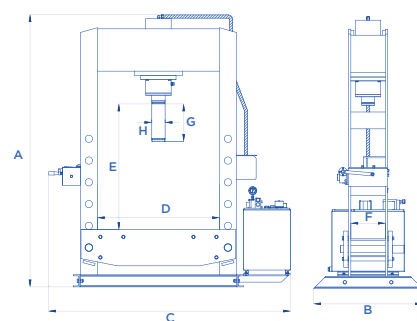

ART.	TON												
		mm/min	mm/min	A mm	B mm	C mm	D mm	E mm	F mm	G mm	H mm	kW	KG
162/W	50	600	215	2130	850	1650	775	1135	205	260	60	1,5 kw	530
164/W	100	570	180	2310	900	1930	1010	1055	280	310	110	3 kw	1050

24 MESI
Garanzia

OMCN
S.p.A.

MADE IN ITALY



MARTINETTI IDRAULICI PER CARROZZERIA

ART. 353 - 12 Ton.

~~€ 1.014,00~~ - € 599,00

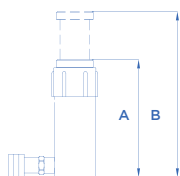

ART.	A mm	B mm
353	360	520



ART. 355 - 6 Ton.

~~€ 793,00~~ - € 469,00

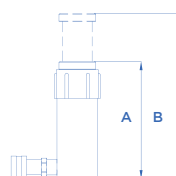

ART.	A mm	B mm
355	290	410



POMPE MANUALI COMPLETE DI TUBO FLESSIBILE

ART. 350/A

~~€ 445,00~~ - € 265,00



ART. 350/A

ART. 358/A

~~€ 494,00~~ - € 292,00

ART. 358/C

~~€ 1.049,00~~ - € 619,00



ART. 358/C

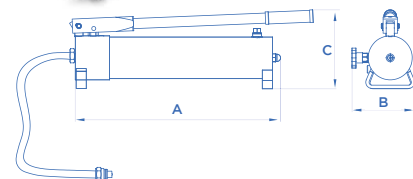

ART.	Tipo pompa	Pressione	Portata olio per pompata		Capacità serbatoio	A mm	B mm	C mm	KG
350/A	Ad una velocità	700 bar	14,13 cm ³	2,26 cm ³	1100 cm ³	510	165	160	9,2
358/A		700 bar		2,26 cm ³	650 cm ³	330	140	160	6,5
358/C	A due velocità	700 bar		3,07 cm ³	2400 cm ³	510	160	200	12,5

24 MESI
Garanzia

OMCN
S.p.A.

MADE IN ITALY



**POMPA IDROPNEUMATICA
COMPLETA DI TUBO FLESSIBILE
E GIUNTO RAPIDO**



ART. 357

~~€ 980,00~~ - **€ 579,00**

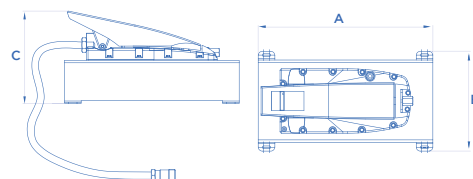

ART.	Pressione	Portata	Capacità serbatoio	A mm	B mm	C mm	KG
357	700 bar	0,7 l/min	1100 cm ³	295	110	170	6,3

**CILINDRI IDRAULICI
A SEMPLICE EFFETTO**

ART. 359/M - 5 TON

~~€ 268,00~~ - **€ 159,00**

ART. 361/M - 20 TON

~~€ 609,00~~ - **€ 359,00**

ART. 360/M - 10 TON

~~€ 345,00~~ - **€ 203,00**

ART. 362/M - 30 TON

~~€ 745,00~~ - **€ 439,00**

INGOMBRO RIDOTTO

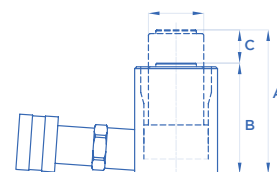

ART.	TON	Pressione	Capacità olio	A mm	B mm	C mm	D mm	KG
359/M	5	700 bar	15,3 cm ³	76	60	16	30	0,6
360/M	10	700 bar	25,4 cm ³	76	60	16	40	0,9
361/M	20	700 bar	26,4 cm ³	78	70	8	60	2,7
362/M	30	700 bar	40,1 cm ³	78	70	8	75	3,8



Ritorno a molla

24 MESI
Garanzia

OMCN
S.p.A.

MADE IN ITALY

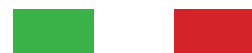

IMPIEGHI GENERICI

ART. 360/CM - 10 TON

~~€ 393,00~~ - € 232,00

ART. 361/CM - 20 TON

~~€ 680,00~~ - € 399,00

ART. 362/CM - 30 TON

~~€ 798,00~~ - € 472,00

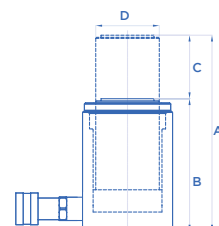

Ritorno a molla

ART.	TON	Pressione	Capacità olio	A mm	B mm	C mm	D mm	KG
360/CM	10	700 bar	119,2 cm ³	195	120	75	40	1,9
361/CM	20	700 bar	198,6 cm ³	185	125	60	60	4,9
362/CM	30	700 bar	301,2 cm ³	185	125	60	75	6,8

ART. 359/EM - 5 TON

~~€ 462,00~~ - € 273,00

ART. 360/EM - 10 TON

~~€ 544,00~~ - € 322,00

ART. 361/EM - 20 TON

~~€ 978,00~~ - € 579,00

ART. 362/EM - 30 TON

~~€ 1.139,00~~ - € 675,00

CORSA LUNGA

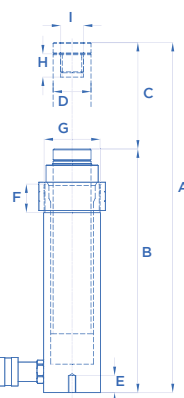

Ritorno a molla

ART.	TON	Pressione	Capacità olio	A mm	B mm	C mm	D mm	E mm	F mm	G mm	H mm	I mm	L mm	M mm	KG
359/EM	5	700 bar	120 cm ³	370	245	125	30	20	25	M50X2	12	M16X2	32	M8	2,5
360/EM	10	700 bar	222 cm ³	405	265	140	40	20	30	M64X2	25	M24X3	45	M8	5,2
361/EM	20	700 bar	529 cm ³	450	290	160	60	20	30	M84X2	30	M30X3,5	50	M10	11,1
362/EM	30	700 bar	702 cm ³	420	275	140	75	20	30	M104X2	25	M39X4	65	M10	16,8

24 MESI
Garanzia

OMCN
S.p.A.

MADE IN ITALY



CURVATUBI IDRAULICI

RAPID T10

A piastra superiore scorrevole e con piastra inferiore a lettura costante, curvano a freddo senza riempimento tubi gas e acqua, senza saldatura, UNI EN10255 (BS1387 - UNI3824).



RAPID T10 MINI

~~€ 823,00~~ - € 485,00

RAPID T10 B

~~€ 1064,00~~ - € 629,00

RAPID T10 C

~~€ 1571,00~~ - € 935,00

ART.	MATRICI CONTENUTE					
RAPID T10 MINI	3/8"	1/2"	3/4"	1"		
RAPID T10 B	3/8"	1/2"	3/4"	1"	1 1/4"	
RAPID T10 C	3/8"	1/2"	3/4"	1"	1 1/4"	1 1/2"

BANCHI DA LAVORO



ART. 1001 - 600 kg

~~€ 658,00~~ - € 389,00

ART. 1002 - 600 kg

~~€ 807,00~~ - € 479,00

ART. 1003 - 400 kg

~~€ 1026,00~~ - € 605,00

ART. 1004 - 400 kg

~~€ 1.172,00~~ - € 695,00



ART.		Numero di cassetti	mm	mm	mm
1001	600 kg	1	1500	850	700
1002	600 kg	2	1500	850	700
1003	400 kg	2	2000	850	700
1004	400 kg	3	2000	850	700

24 MESI
Garanzia

OMCN
S.p.A.

MADE IN ITALY



**CARRELLO A QUATTRO RIPIANI,
COMPLETO DI DOPPIO PANNELLO
PORTAUTENSILI**

ART. C51/A

~~€ 849,00~~ - € 499,00

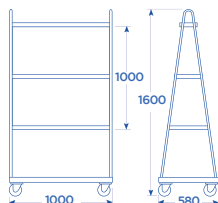

**CARRELLO A DUE RIPIANI,
COMPLETO DI PANNELLO
PORTAUTENSILI**

ART. C52

~~€ 1.041,00~~ - € 619,00

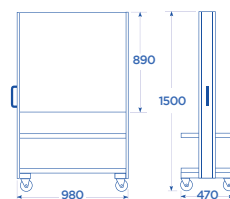

SDRAIO

ART. 099 - 150 kg

~~€ 127,00~~ - € 75,00



**SDRAIO CON STRUTTURA IN TUBOLARE
E SCHIENALE COMPLETAMENTE IMBOTTITO**

ART. 099/B - 150 kg

~~€ 215,00~~ - € 127,00



ART.			
	mm	mm	mm
099	150 kg	1000	440
099/B	150 Kg	1000	440

24 MESI
Garanzia

OMCN
S.p.A.

MADE IN ITALY



CARRELLO CON SPONDA

ART. 207 - 250 kg

~~€ 389,00~~ - € 229,00



CARRELLO CHIUSO PORTA ATTREZZI A QUATTRO PIANI CON SERRATURA

ART. 210 - 200 kg

~~€ 546,00~~ - € 320,00



CARRELLO ECOLOGICO

ART. 600 - 75 kg

~~€ 512,00~~ - € 299,00





CARRELLO MILLEUSI

ART. 092 - 300 kg

~~€ 343,00~~ - € 199,00



CARRELLO PORTA BOMBOLE

ART. 095 - 200 kg

~~€ 256,00~~ - € 150,00

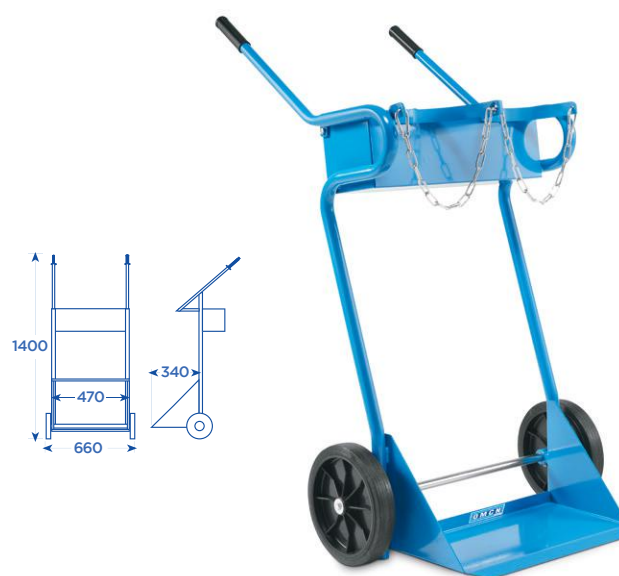

CARRELLO PORTA BOMBOLA

ART. 095/A - 200 kg

~~€ 240,00~~ - € 140,00



CARRELLO PORTA SACCHI

ART. 212 - 200 kg

~~€ 185,00~~ - € 109,00



24 MESI
Garanzia

OMCN
S.p.A.

MADE IN ITALY



CARRELLO PORTA CASSE

ART. 213 - 200 kg

~~€ 199,00~~ - € 117,00

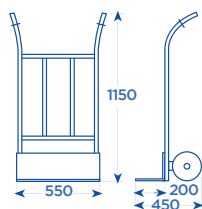

CARRELLO MULTIUSO PER TRASPORTO SU SCALE

ART. 214/A - 250 kg

~~€ 335,00~~ - € 197,00

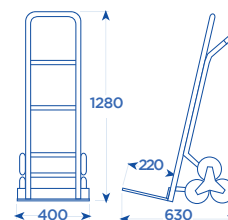

CARRELLO PORTA CASSE STRETTO

ART. 214/B - 250 kg

~~€ 263,00~~ - € 155,00

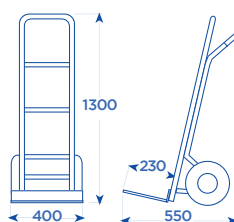

CARRELLO PORTA SACCHI E PORTA FUSTI

ART. 214/D - 250 kg

~~€ 311,00~~ - € 183,00

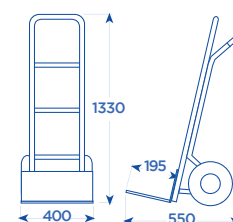

24 MESI
Garanzia

OMCN
S.p.A.

MADE IN ITALY



CARRELLO PORTA ATTREZZI

ART. 109/A - 120 kg

~~€ 183,00~~ - € 107,00



ART.					
109/A	120 kg	700 mm	750 mm	350 mm	60 mm

CARRELLO PORTA ATTREZZI TIPO PESANTE

ART. 109/B - 150 kg

~~€ 236,00~~ - € 139,00



ART.					
109/B	150 kg	800 mm	750 mm	420 mm	80 mm

CARRELLO PORTA ATTREZZI TIPO PESANTE, CON CASSETTO

ART. 109/C - 150 kg

~~€ 303,00~~ - € 179,00



ART.					
109/C	150 kg	800 mm	750 mm	420 mm	80 mm

CARRELLO GIGANTE A TRE PIANI

ART. 208 - 180 kg

~~€ 345,00~~ - € 204,00



ART.					
208	180 kg	1000 mm	830 mm	600 mm	125 mm

CARRELLO GIGANTE A TRE PIANI CON CASSETTO

ART. 209 - 180 kg

~~€ 405,00~~ - € 239,00



ART.					
209	180 kg	1000 mm	830 mm	600 mm	125 mm

CARRELLO CON SPONDA E RETE METALLICA PERIMETRALE

ART. 211 - 250 kg

~~€ 453,00~~ - € 269,00



ART.					
211	250 kg	1000 mm	850 mm	600 mm	125 mm

24 MESI
Garanzia

OMCN
S.p.A.

MADE IN ITALY



CARRELLO JOLLY

ART. 250 - 800 kg

~~€ 539,00~~ - € 318,00

JOLLY



ART.					
250	800 kg	600	330	1300	200

TRAVERSA REGOLABILE

ART. 275 - 500 kg

~~€ 390,00~~ - € 230,00

SUPER
CONDOR

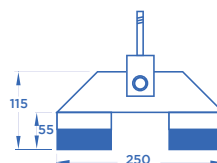

ART.		MAX	MIN
275	500 kg	1600	920

CAVALLETTO SPEEDY REGOLAZIONE A TRE POSIZIONI

ART. 381

~~€ 236,00~~ - € 139,00

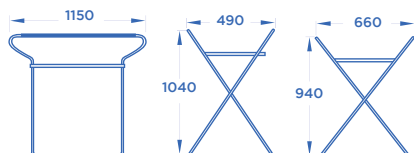

24 MESI
Garanzia

OMCN
S.p.A.

MADE IN ITALY



SLALOM

Per manovrare e posizionare ogni tipo di vettura in spazi ristretti. Particolarmente indicato per carrozzerie, saloni d'auto, officine di riparazione e garages.

Esecuzione con pedale destro o sinistro per la risoluzione di ogni tipo di problema e la possibilità d'impiego anche con ruote sottosterzo.

I rulli e la struttura di base del carrello sono stati studiati per sollevare pneumatici fino a **220 mm.** di larghezza.

ART. 388

~~€ 657,00~~ - € 389,00 CAD.



Attrezzo per carico e scarico di autovetture sinistrate per qualsiasi tipo di carroattrezzi.

I rulli e la struttura di base del carrello sono stati studiati per sollevare pneumatici fino a **220 mm.** di larghezza.

ART. 388/A

~~€ 718,00~~ - € 428,00 CAD.

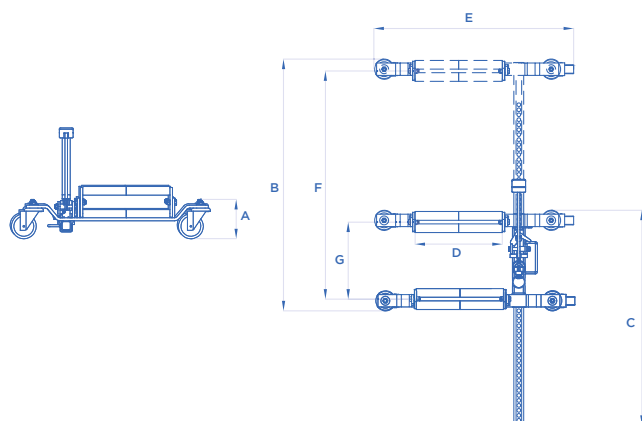

ART.		A mm	B mm	C mm	D mm	E mm	F mm	G mm	KG
388	550 Kg	150	820	710	200	635	650	220	19
388/A	550 Kg	130	820	710	200	400	650	220	18

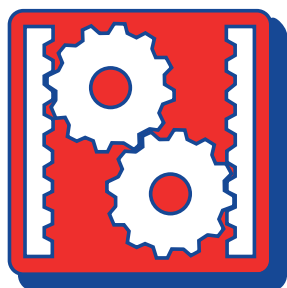

Forniture Industriali - Macchine Utensili

DI EMIDIO

www.diemidio.it

Di Emidio s.r.l. Zona Industriale Colleranese di Julianova (TE)
Tel: (39) 085 8004550 - Fax: (39) 085 8025055 - info@diemidio.it



24020 VILLA DI SERIO (BG) ITALY

Via Divisione Tridentina, 23

T. 035 423 44 11 • F. 035 423 44 41 • 035 423 44 42

www.omcn.it • info@omcn.it

EXPORT

T. +39 035 423 44 16 • F. +39 035 423 44 49

www.omcn.com • info@omcn.com